

# System Integration

## University of Paisley ICT Services



***Presentation to HEIDS  
18 January 2007***

***'A Tale of Woe!?'***

# Agenda

- Current Situation
- Proposed Improvements
- Technical Constraints
- Politics and Resources
- Commercial Difficulties
- Lessons Learned
- Future Steps

# Key Systems & Interfaces

- Key Systems
  - Banner (Student Record System)
  - Agresso (Finance System)
  - TALIS (Library System)
  - Blackboard (VLE)
- Existing in-house interfaces (point-to-point)
  - Banner  Agresso
  - Banner  TALIS
  - Banner  Blackboard
- Actually only single emailed flat file!

Current  
Situation

Proposed  
Improvements

Technical  
Constraints

Politics &  
Resources

Commercial  
Difficulties

Future Steps

Lessons  
Learned

# Initial Intentions

- Replace existing legacy data transfer
- Calopus from Leeds Metropolitan University
- Interface for Banner - Agresso available
- Software purchased and training undertaken
- Reference site visit requested
- Significant delays in arranging site visit
- Single point of failure identified at supplier
- Still a point-to-point batch process
- Lack of confidence in delivery & support

Current  
Situation

Proposed  
Improvements

Technical  
Constraints

Politics &  
Resources

Commercial  
Difficulties

Future Steps

Lessons  
Learned

# Alternative Solutions

- Move to bi-directional 'real-time' integration
- Remove reliance on internal development
- Middleware solutions investigated
- Short timeframe for delivery & limited budget
- Oracle & Sun solutions rejected (price & time)
- Luminis Data Integration Suite (LDIS)
- Part of Luminis portal from SungardHE
- Baseline product supported by supplier
- Blackboard adaptor available 'out-the-box'

Current  
Situation

Proposed  
Improvements

Technical  
Constraints

Politics &  
Resources

Commercial  
Difficulties

Future Steps

Lessons  
Learned

# Bi-directional 'real-time' Integration

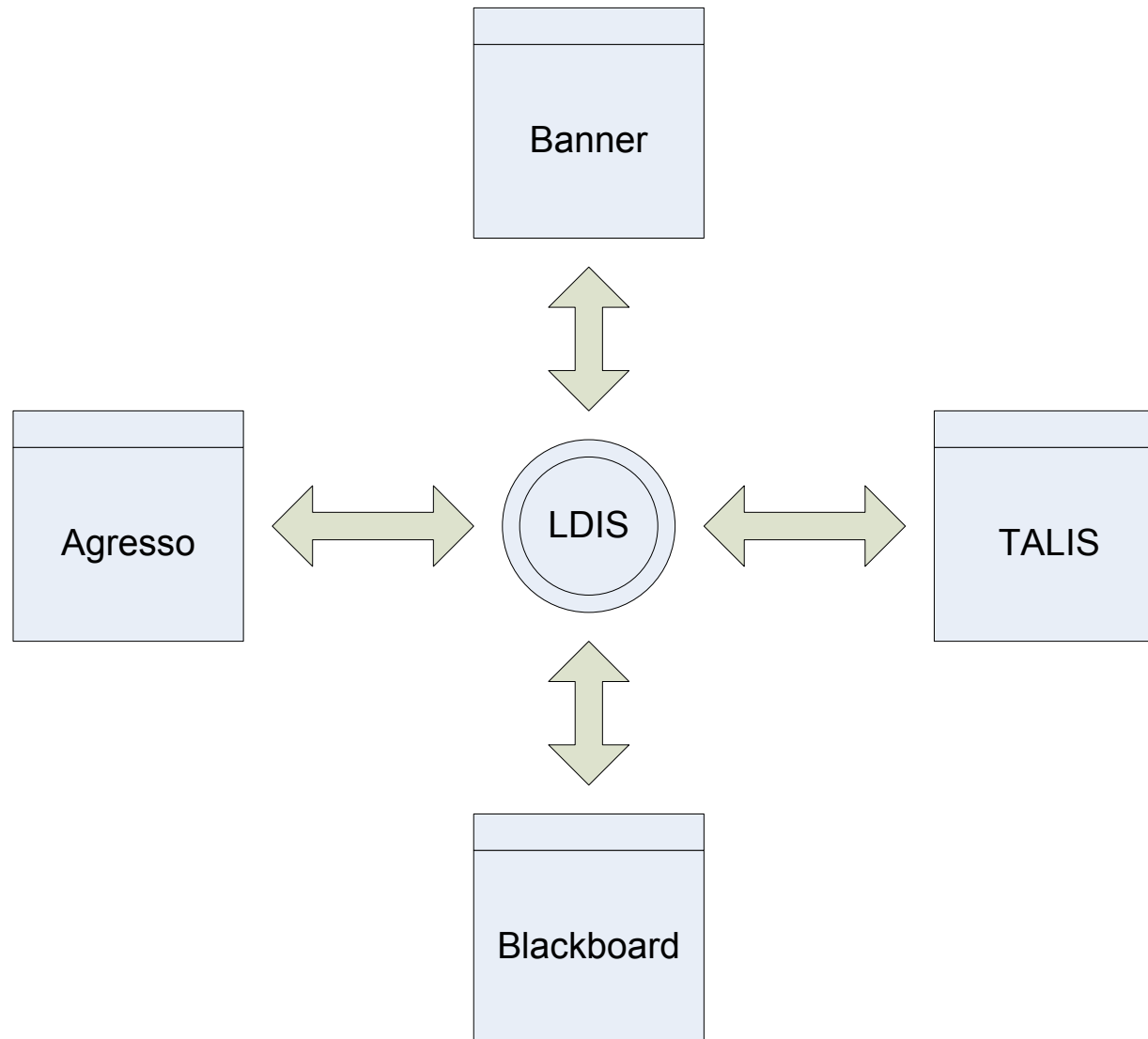

Current Situation

Proposed Improvements

Technical Constraints

Politics & Resources

Commercial Difficulties

Future Steps

Lessons Learned

# System Limitations

- TALIS cannot handle 'real-time' data integration
- 3<sup>rd</sup> Party software tool available at cost
- Agresso has no published APIs for integration
- Consultants sometimes difficult to get hold of
- Blackboard import routines need configured
- Blackboard data export not same as WebCT
- Poor data quality coming out of Banner
- Limited information held in Banner (Faculty)
- Network logins and email accounts excluded

Current  
Situation

Proposed  
Improvements

Technical  
Constraints

Politics &  
Resources

Commercial  
Difficulties

Future Steps

Lessons  
Learned

# Internal & External Issues

- Internal staff unhappy with 'real-time' integration
- Single points of failure (staff) for all systems
- Integration being driven by SIS Project (Banner)
- All parties fail to communicate effectively
- Lack of agreed specifications and deliverables
- Unrealistic timeframe for delivery
- Insufficient budget to deliver workable solution
- Complete lack of 'buy-in' from key individuals

Current  
Situation

Proposed  
Improvements

Technical  
Constraints

Politics &  
Resources

Commercial  
Difficulties

Future Steps

Lessons  
Learned

# Dealing with External Suppliers

- Supplier consultants disagree on methodology
- Commercial issues arising between suppliers
- SungardHE consultants all based in US
- Sales Manager 'moves on' during process!
- Account Manager loses focus on project
- Some consultancy pre-packaged & overpriced
- Key elements of 'agreement' undocumented
- Contractual minefield to be negotiated
- Ultimatum brings things to a head!

Current  
Situation

Proposed  
Improvements

Technical  
Constraints

Politics &  
Resources

Commercial  
Difficulties

Future Steps

Lessons  
Learned

# Batch Processing

Banner - Blackboard Data  
Integration architecture -  
Approach 1

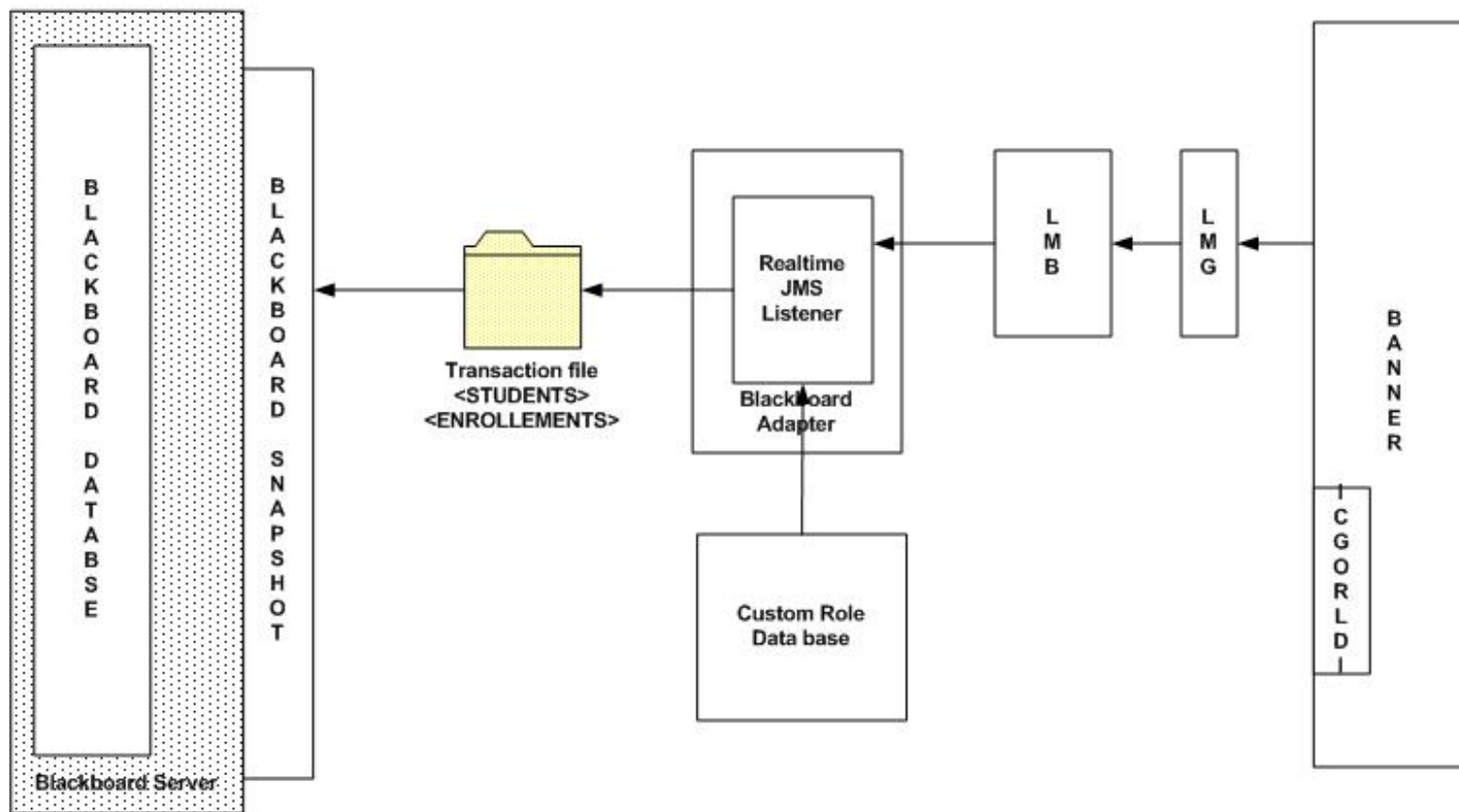

Current Situation

Proposed Improvements

Technical Constraints

Politics & Resources

Commercial Difficulties

Future Steps

Lessons Learned

# Real-time Processing

Banner - Blackboard Data Integration architecture

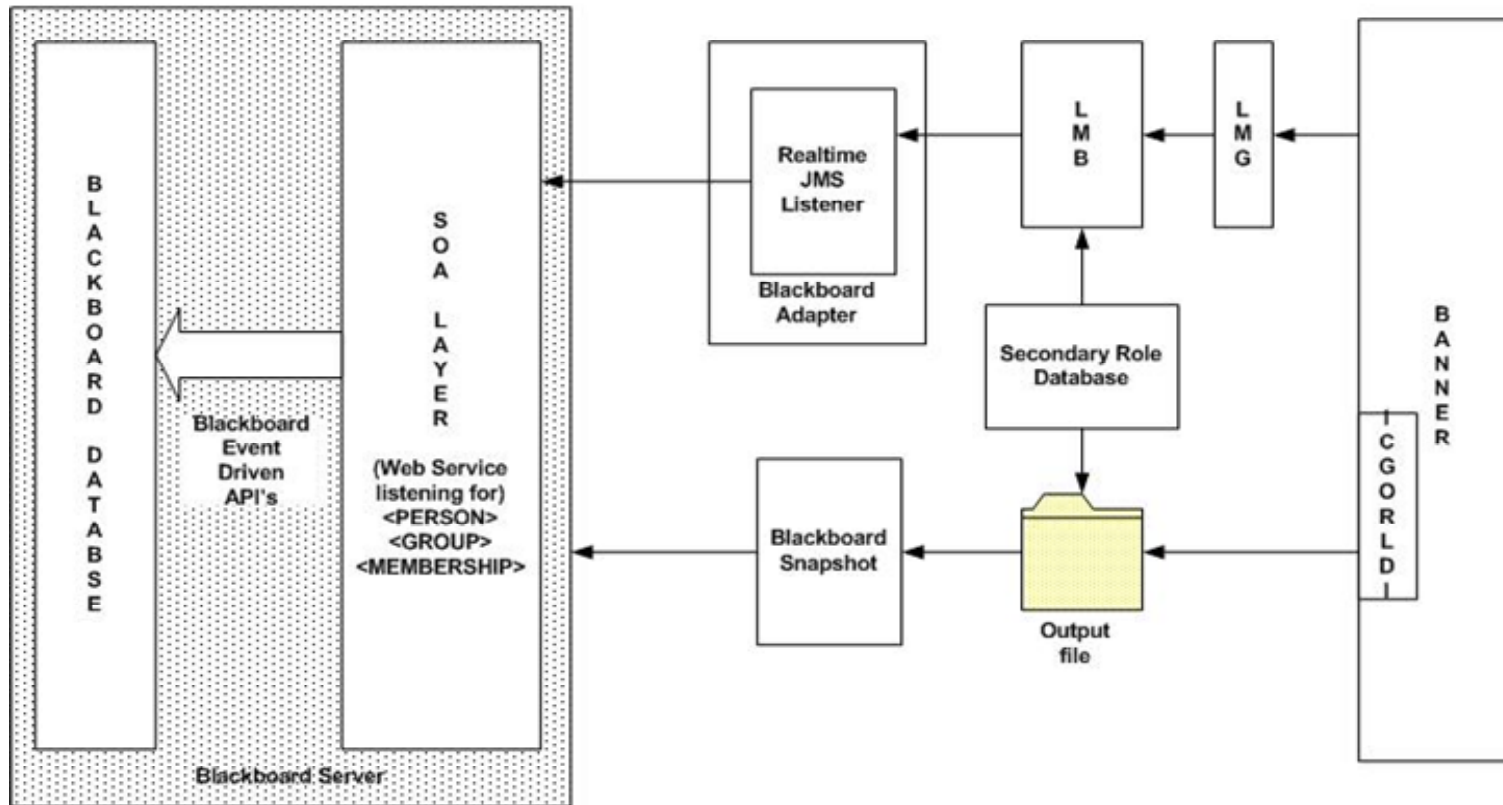

- Current Situation
- Proposed Improvements
- Technical Constraints
- Politics & Resources
- Commercial Difficulties
- Future Steps
- Lessons Learned

# 20/20 Hindsight!

- Don't drive integration from one end of process
- Involve key stakeholders from all sides at start
- Take the 'politics' out of business processes
- Map technical architecture in detail at start
- Ensure core processes working on each system
- Deal with external suppliers in parallel
- Read the supply contract(s) very carefully
- Ensure availability of consultants
- Don't attempt to deliver the impossible!

Current  
Situation

Proposed  
Improvements

Technical  
Constraints

Politics &  
Resources

Commercial  
Difficulties

Future Steps

Lessons  
Learned

# Any Questions

